

MYERS® Quick Prime Self-Priming Centrifugal Pump

The Quick Prime self-priming centrifugal pump is designed for demanding jobs where a lot of water is required over a long period of time. For lawn and garden sprinkling, car washing, or other big cleaning and maintenance jobs, it's built for one purpose only – continuous high performance service. Not for use with corrosive chemicals or flammable liquids.

APPLICATIONS

■ **Water systems...** lawn and gardening sprinkling, car washing, or other big cleaning and maintenance jobs

SPECIFICATIONS

- High tensile gray iron pump case and motor bracket
- Square rubber sealing rings
- Proven thermoset diffuser
- Engineered composite impeller
- Carbon/ceramic shaft seal



FEATURES

Ruggedly Built – To meet the demands for long, hard continuous service without over-working or overloading the motor.

Manufactured – To precise performance specifications.

Impellers – Corrosion resistant for long life.

Simply Design – Powerful, efficient operation and easy servicing.

Proper Impeller Alignment – For smooth, quiet running.

Unique Diffuser Design – For quick automatic prime. No additional water needed for repriming after installation.

Common Brackets – Cases and gaskets on all sizes... simplified parts selection.

ORDERING INFORMATION

Catalog Number		HP	Pipe Sizes		Maximum Total Shut-Off Hd.		1 and 3 Ø Approx. Wt. Lbs.
1 Phase	3 Phase		Suct.	Disch.	Feet	PSI	
QP7	QP7-3	3/4	1-1/2"	1-1/2"	105	45.5	58
QP10	QP10-3	1	1-1/2"	1-1/2"	108	47	61
QP15	QP15-3	1-1/2	1-1/2"	1-1/2"	111	48	68
QP20	QP20-3	2	1-1/2"	1-1/2"	116	50	74
QP30	QP30-3	3	1-1/2"	1-1/2"	121	52	87

MYERS® Quick Prime Self-Priming Centrifugal Pump

OUTLINE DIMENSIONS

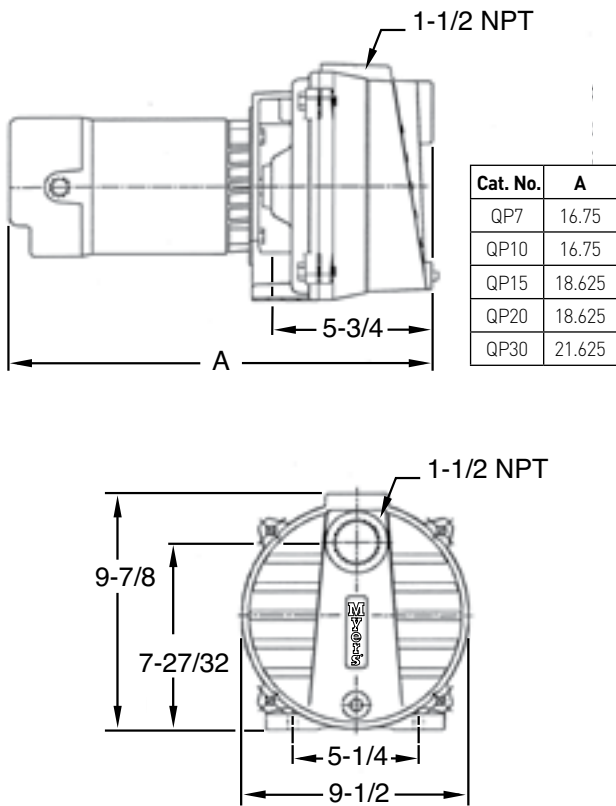

Dimensions (in inches) are for estimating purposes only.

PUMP PERFORMANCE

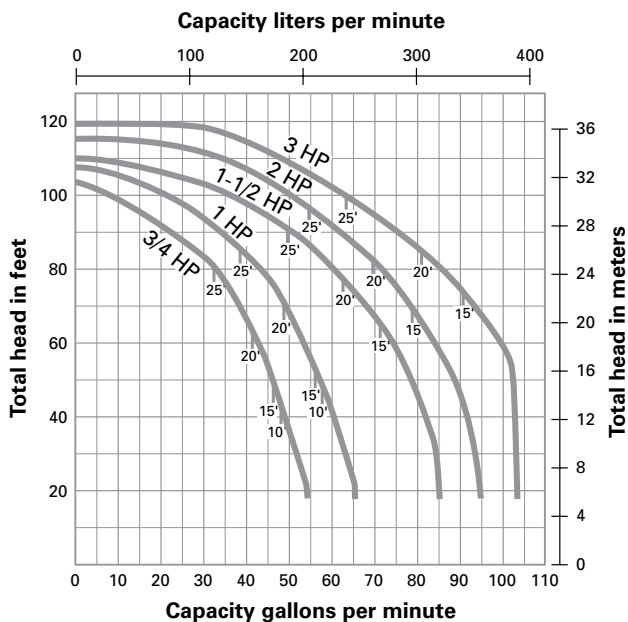

PUMP PERFORMANCE

Catalog Number		HP	Disch. Pressure PSI	Capacity in GPM for Discharge Pressure and Total Suction Lift Indicated			
1 Phase	3 Phase			10 Ft.	15 Ft.	20 Ft.	25 Ft.
QP7	QP7-3	3/4	20	40.75	38.1	36.1	33.2
			25	35.75	33.5	30.9	27.5
			30	30.75	27.25	23.1	18
			35	21.5	15.1	8.5	
			40	6.5			
QP10	QP10-3	1	20	51.2	48.9	46.4	39.25
			25	46.2	43.5	40.6	37.4
			30	40.5	37.5	33.6	29.2
			35	33	27.6	20.6	10
			40	19	5		
QP15	QP15-3	1-1/2	20	71.6	69.4	63.4	50.25
			25	66.5	62.5	58.75	50.25
			30	59.5	55	50.5	45
			35	50.5	43.6	37	24.9
			40	36.8	25.9		
QP20	QP20-3	2	20	78.9	76.6	70.5	55.5
			25	74.6	71.5	67	55.5
			30	68.5	63.5	58.4	53
			35	58.5	52.9	47	40
			40	47.5	40.5	32.5	
QP30	QP30-3	3	20	93	91	82	64
			25	92.9	91	82	64
			30	89.8	85.5	78.6	64
			35	81	73.3	65.6	57
			40	67.9	59.1	48.5	37.5
			45	47.9	30		

NOTE: Single phase units are dual voltage (115/230 volt) 2 and 3 HP are 230 volt only.

NOTE: All units are loaded within the motor service factor and are rated for continuous operation.

